

ultraframe

Classic



New Lantern Roofs



**world class
conservatory
systems**

LANTERN ROOF COMPONENTS

D MOULD EXTERNAL EAVES
CLADDING
SUPPLIED BY OTHERS

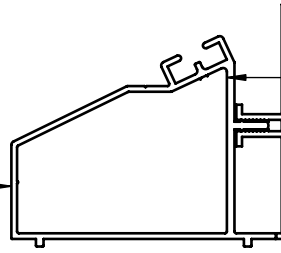

ALUMINIUM LANTERN
HEADER BEAM
LHE 600
£85.22

LANTERN HEADER
BEAM CLADDING
TFC 400
£7.50

**WINDOW FRAMES AND CILL
SUPPLIED BY OTHERS**

LANTERN SEALING
FOAM 10 M ROLL
VPLF 010
£24.42

RAIN BAFFLE TO SUITE
GLAZING THICKNESS
eg. **KRSB637/24L**
£18.25

RAIN BAFFLE
BACK SECTION
KRB600/35BL
£8.42

MK 5 HALF RIDGE
BAFFLE WING
KHB600/35
£57.35

HALF RIDGE
UNDERCLADDING
KHU 600
£45.11

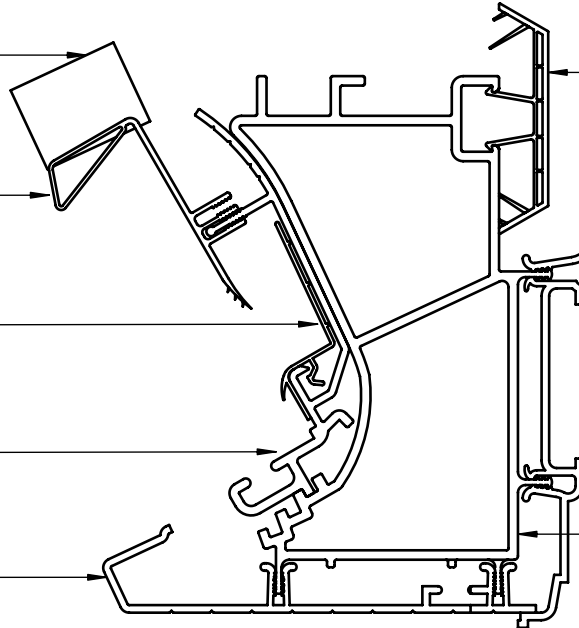

LANTERN BEAM
INTERNAL CLADDING
SSPC600
£31.69

EAVES BEAM
FASCIA BOARD
SFB600
£27.60

OR
PFTB600
£18.62

VARIABLE PITCH
LANTERN BEAM
VPLB 600/1
£134.55

90 GEORGIAN ENDS

LANTERN HEADER CLEATS **TCCA 90** £0.74 **X 2**
HEADER CLEAT SCREWS **CRS 001** £0.05 **X 8**
LANTERN EAVES CLEATS **VPLB 090** £10.55 **X 4**
LANTERN CLEAT SCREWS **SSF 001** £0.05 **X 16**

135 VICTORIAN ENDS

LANTERN HEADER CLEATS **TCCA 135** £0.74 **X 4**
HEADER CLEAT SCREWS **CRS 001** £0.05 **X 16**
LANTERN EAVES CLEATS **VPLB 135** £10.55 **X 8**
LANTERN CLEAT SCREWS **SSF 001** £0.05 **X 32**

**REMEMBER TO CHECK IF TIE BARS HAVE BEEN SPECIFIED
AND IF COMPRESSION STRUTS ARE REQUIRED
TO FABRICATE A COMPRESSION STRUT YOU WILL NEED :-**

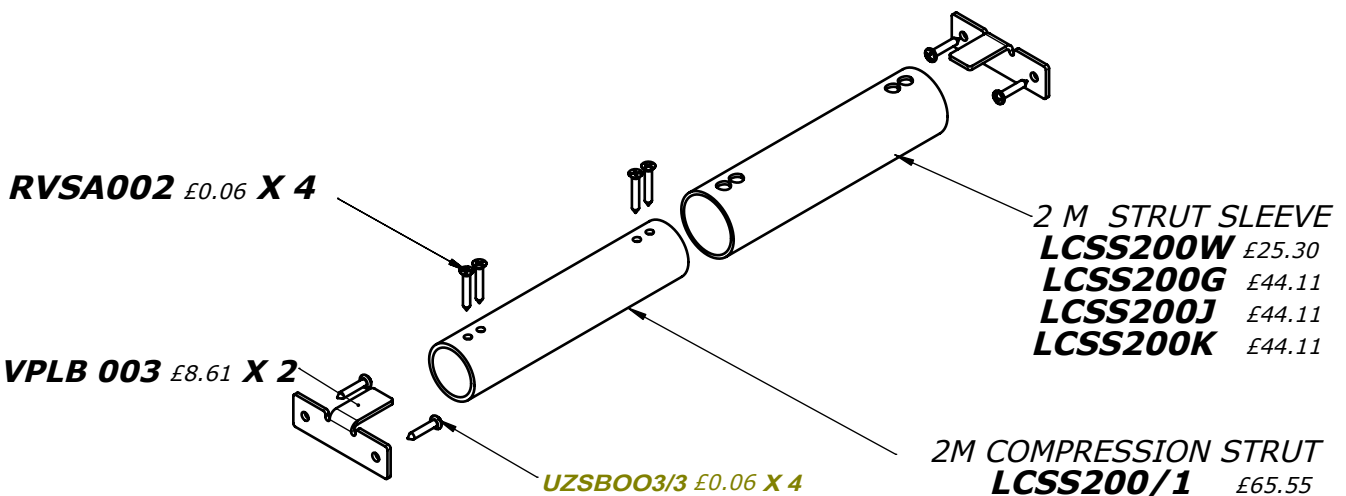

IF 5 WAY TIE BARS ARE FITTED, EACH DROP ROD REQUIRES :-

**DROP ROD BRACKET
AND SCREWS**

VPLB 002 £2.63 **X 1**
RCS 001 £0.06 **X 2**

LANTERN ROOF STRUCTURAL GUIDLINES

FOR ROOF PITCH 25° AND ABOVE 4/4 GLASS. FOR LOWER PITCHES CONSULT STRUCTURAL ENGINEER

7 SERIES BARS FOR LOWER ROOF, 7 SERIES LIGHT FOR LANTERN TOP
LOWER ROOF PITCH 15° TO 30° RECOMMEND EQUAL ON ALL FACETS
LANTERN TOP 25° FIXED PITCH
IF LANTERN BEAM IS LONGER THAN 3M STRUTS ARE REQUIRED
MAXIMUM TIE BAR CENTRES 3M
LANTERN WIDTH = 1/3 TOTAL SPAN - MAX 2M
TIE BARS AND STRUTS MUST ALIGN WITH GLAZING BARS

TIE BARS ----- ————— STRUTS

SINGLE ENDED GEORGIAN STYLE

0.8 kN/M²
 750 BAR CENTRES
 5 WAY TIE BARS
 1 STRUT REQUIRED
 TIE BAR IN LANTERN
 OVER 3M LONG
 USE EAVES WALL CLEATS
 SEWC001 TO FIX TO HOUSE

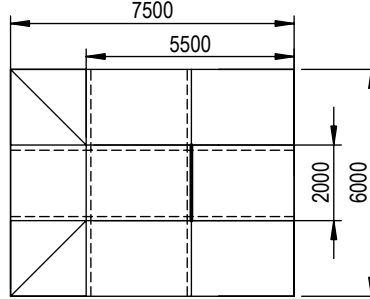
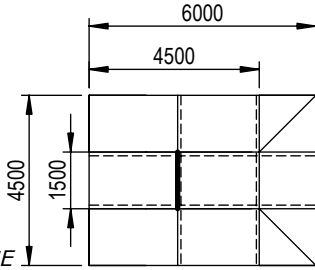

0.8 kN/M²
 1000 BAR \varnothing POLYCARCARB
 875 BAR \varnothing GLASS
 5 WAY TIE BARS
 1 STRUT REQUIRED
 TIE BAR IN LANTERN
 OVER 3M LONG
 USE EAVES WALL CLEATS
 SEWC001 TO FIX TO HOUSE

DOUBLE ENDED GEORGIAN STYLE

0.8 kN/M²
 750 BAR CENTRES
 5 WAY TIE BARS
 NO INSERTS OR OTHER
 ENHANCEMENTS REQUIRED

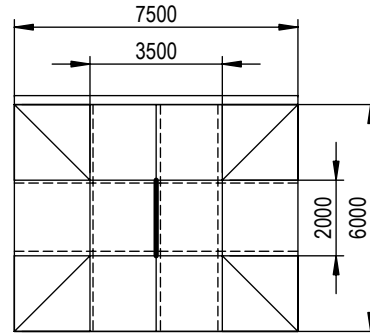
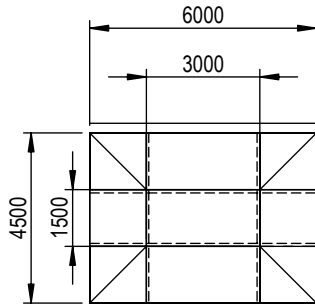

0.6 kN/M²
 5 WAY TIE BARS
 875 BAR \varnothing POLYCARCARB
 667 BAR \varnothing GLASS
 1 STRUT REQUIRED
 TIE BAR IN LANTERN
 OVER 3M LONG

VICTORIAN STYLE

0.8 kN/M²
 3 WAY TIE BARS
 750 BAR CENTRE
 2 STRUTS REQUIRED
 TIE BAR IN LANTERN
 OVER 3M LONG
 USE EAVES WALL CLEATS
 SEWC001 TO FIX TO HOUSE

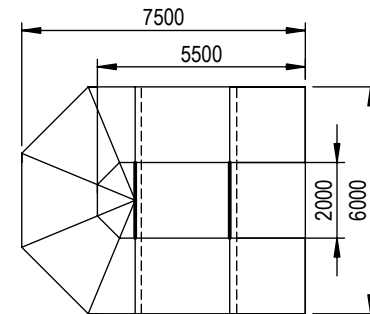
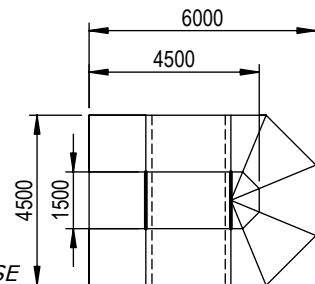

0.8 kN/M²
 3 WAY TIE BARS
 750 BAR CENTRE
 2 STRUTS REQUIRED
 TIE BAR IN LANTERN
 OVER 3M LONG
 USE EAVES WALL CLEATS
 SEWC001 TO FIX TO HOUSE

ROOFS WITH BOX GUTTERS
 REQUIRE INSERTS FOR
 TRANSOMS ADJACENT
 TO THE BOX GUTTER
 (SNOW DRIFT REQUIREMENT)
 IF DIM A IS GREATER THAN 1.5M

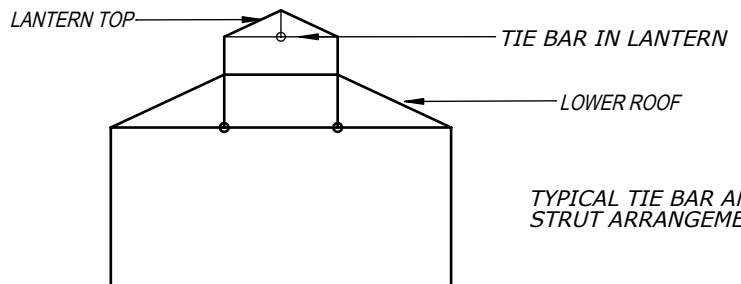
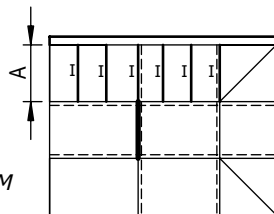

TYPICAL TIE BAR AND
 STRUT ARRANGEMENT

**IF BOX GUTTER IS REQUIRED ON VICTORIAN STYLE
 CONSULT ULTRAFRAME STRUCTURAL ENGINEER**

VPLB ASEMBLIES FOR DIFFERENT PITCHES

15° ROOF PITCH

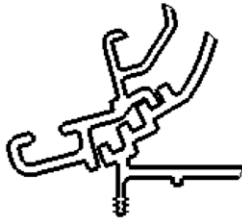

20° ROOF PITCH

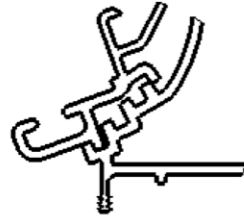

25° ROOF PITCH



30° ROOF PITCH



KHB-35 TO BE FASTENED
WITH SCREWS RCS001
@ MINIMUM OF 500 mm CENTERS
FIRST FASTNER MAXIMUM 75 mm
FROM END OR MITRE

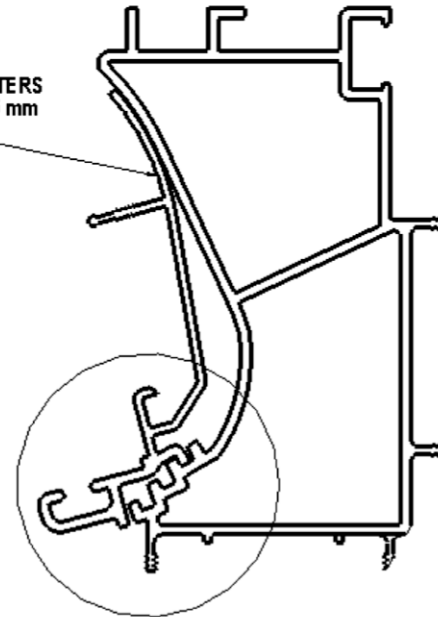

VPLB MK 5 LANTERN MANUFACTURING INFORMATION

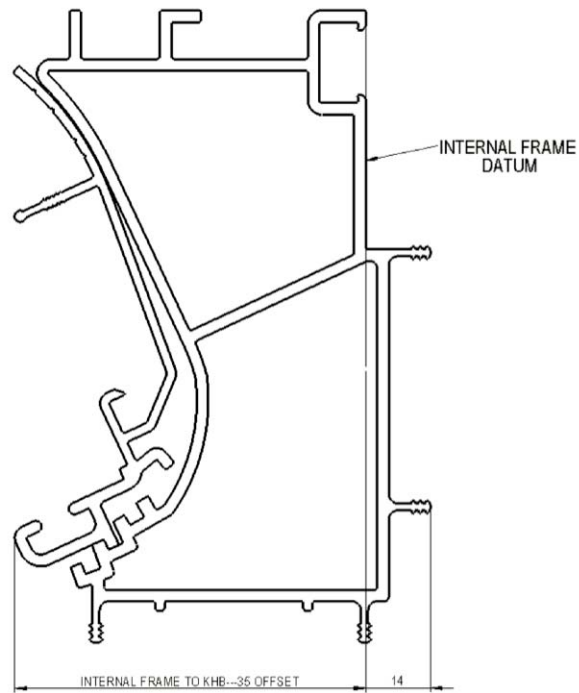

PITCH	INTERNAL FRAME TO KHB---35 EDGE
15	85.55
20	80.5
25	75.79
30	71.3

VARIABLE PITCH MK 5 LANTERN SET OUT INFORMATION

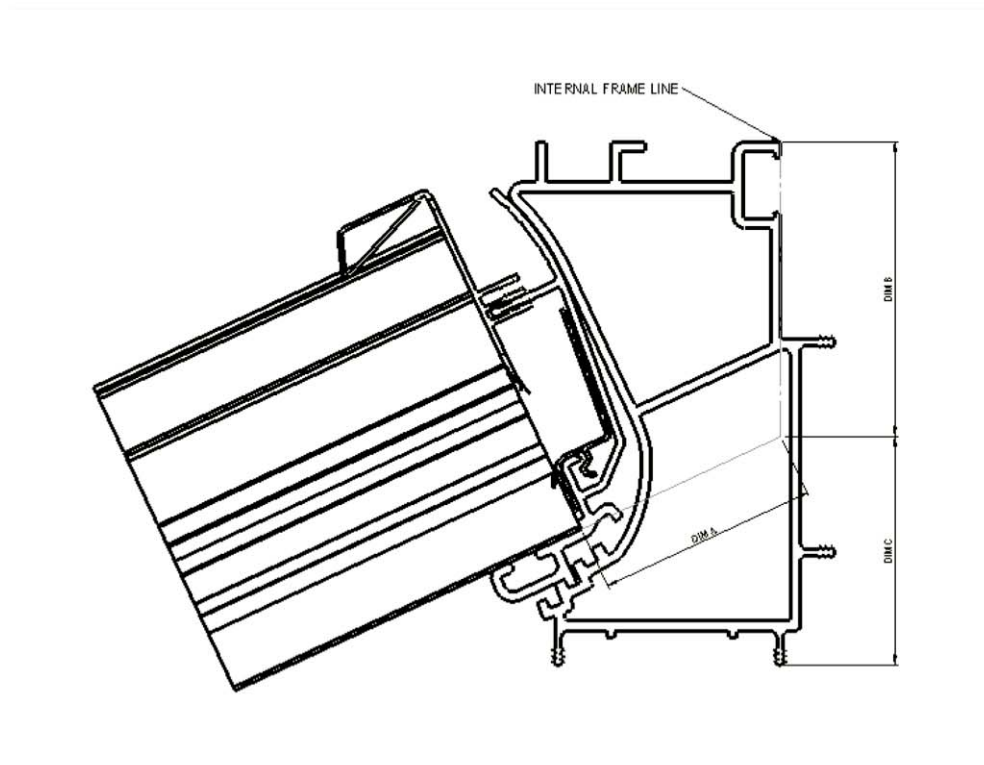

PITCH	BAR DEDUCTION DIM A	HEIGHT ADJUSTMENT DIM B	HEIGHT ADJUSTMENT DIM C
15	62	95.5	41.5
20	59.5	86.5	50.5
25	57.5	77	60
30	56.5	67.5	69.5

BAR LENGTH CALCULATION

$$\text{PLAN LENGTH} = \frac{\text{ROOF SPAN} - \text{LANTERN INTERNAL FRAME SIZE}}{2}$$

$$\text{BAR LENGTH} = \frac{\text{PLAN LENGTH}}{\text{COS PITCH}^\circ} - \text{DIM A} + 81\text{mm}$$

$$\text{LANTERN TOP} = \text{PLAN LENGTH} \times \text{TAN PITCH} + \text{DIM B} + 108.65 \text{ mm}$$

GEORGIAN HIP PREP FOR LANTERN ROOFS

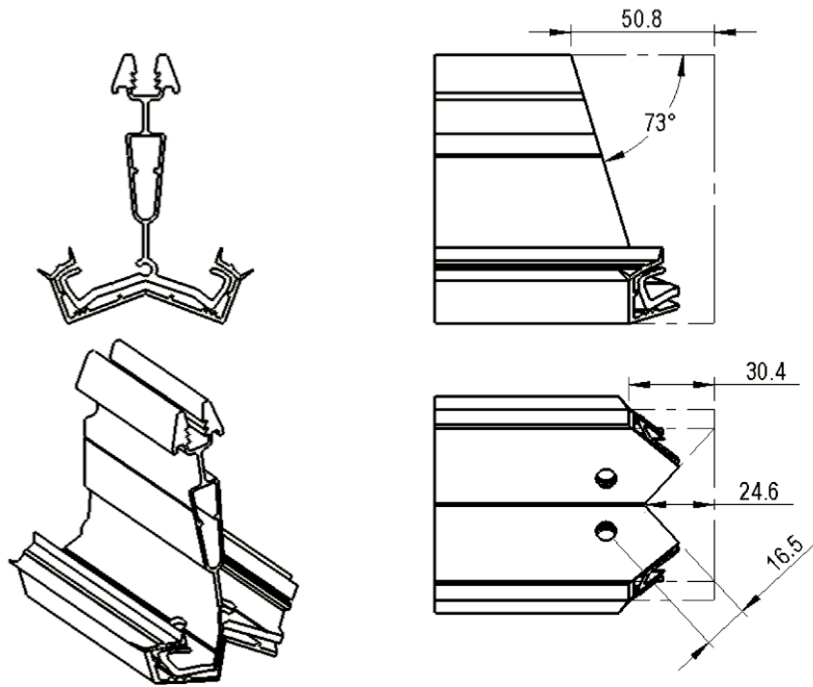

SPGA PREP

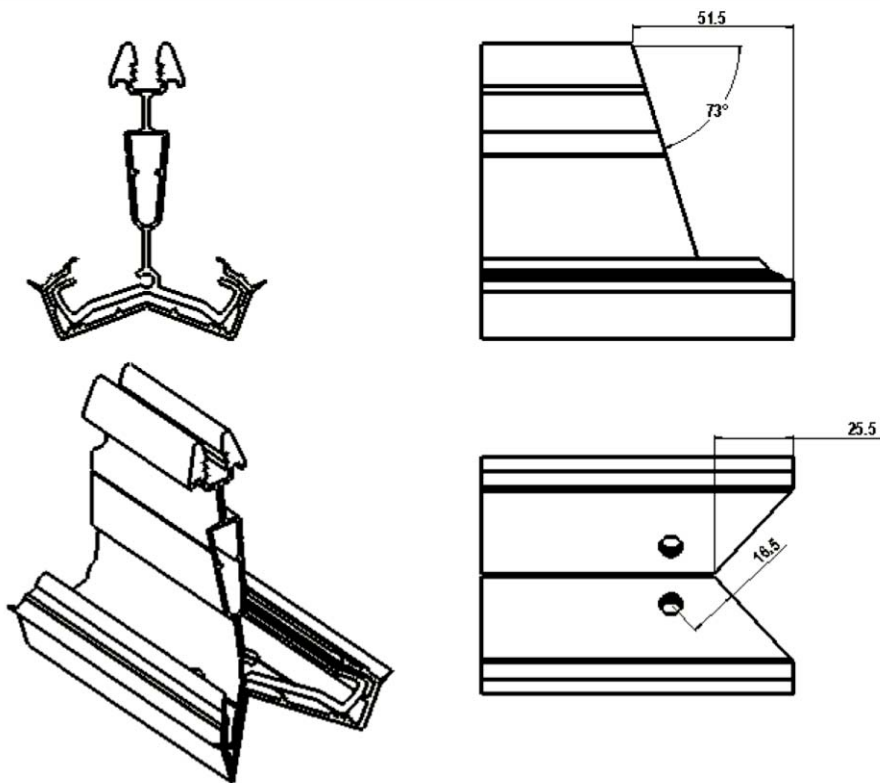

GEORGIAN HIP CAP PREPS FOR LANTERN ROOFS

CCG---25 PREP

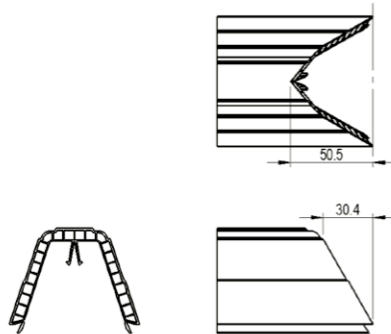

CAPA 6 PREP

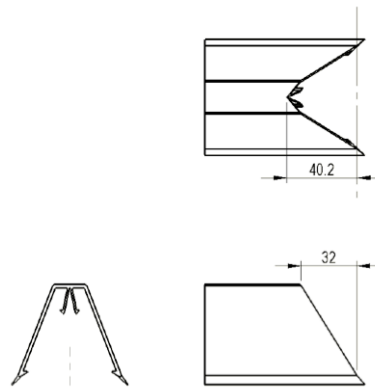

CCG---35 PREP

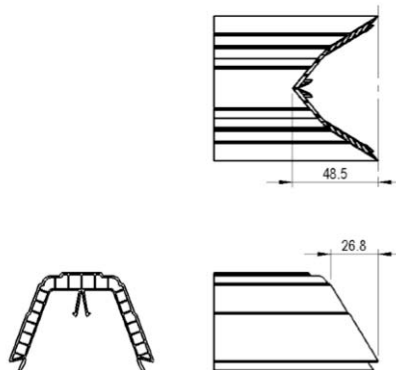

VICTORIAN HIP PREP FOR LANTERN ROOFS

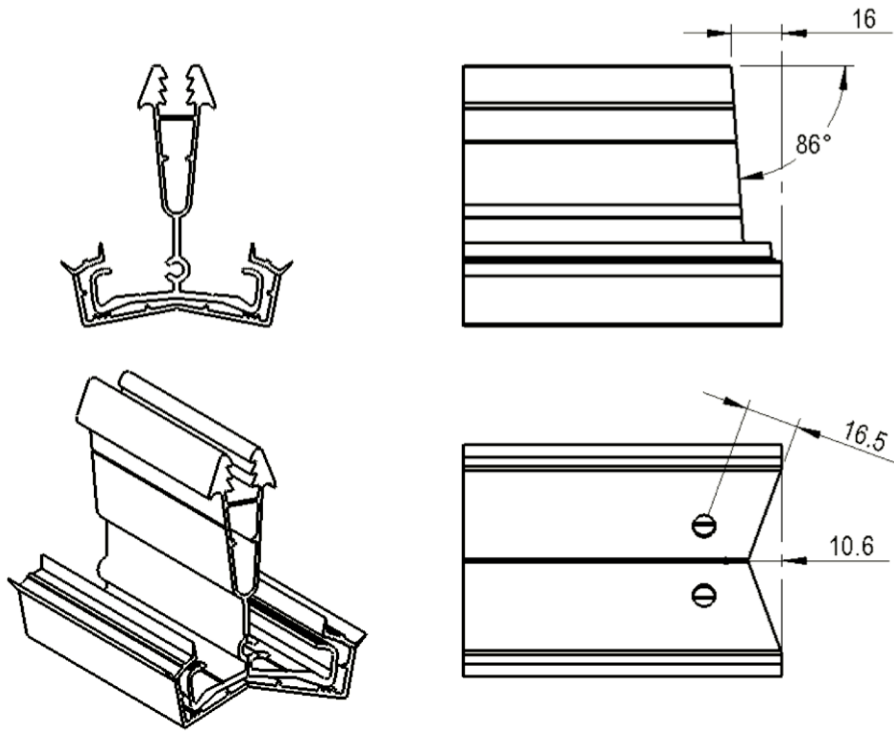

SPTA PREP

VICTORIAN HIP CAP PREPS FOR LANTERN ROOFS

CCA/CCD/CCT---25 PREPS

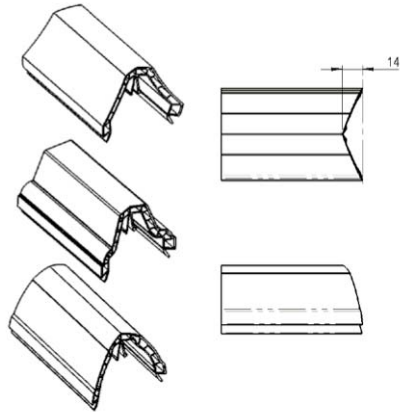

CAPA 6 PREP

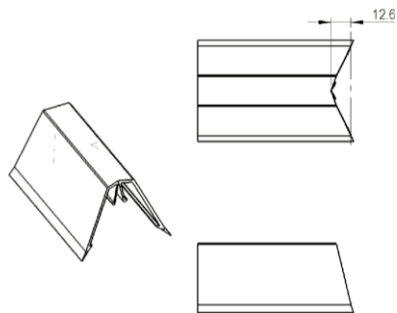

CCA/CCD/CCT---35 PREP

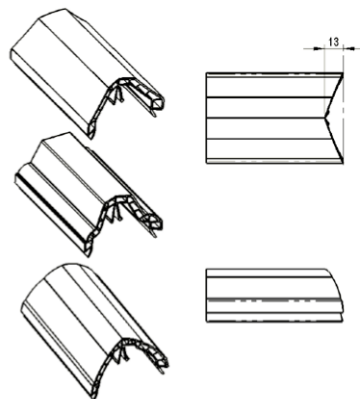

LANTERN MITRE ASSEMBLY

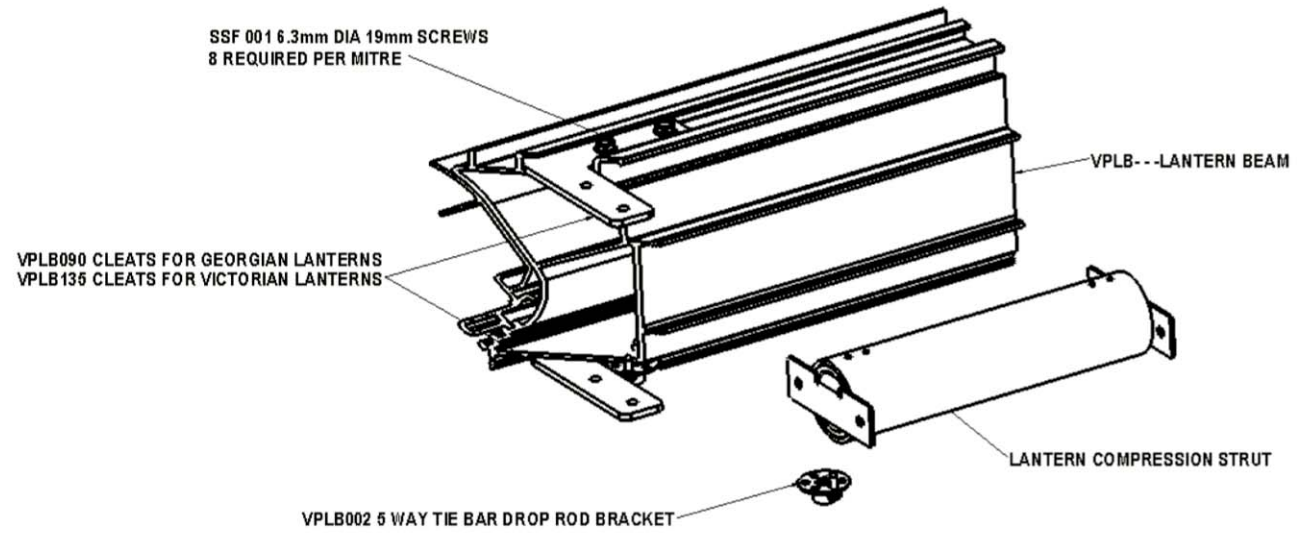

LANTERN BEAM COMPRESSION STRUT ASSEMBLY

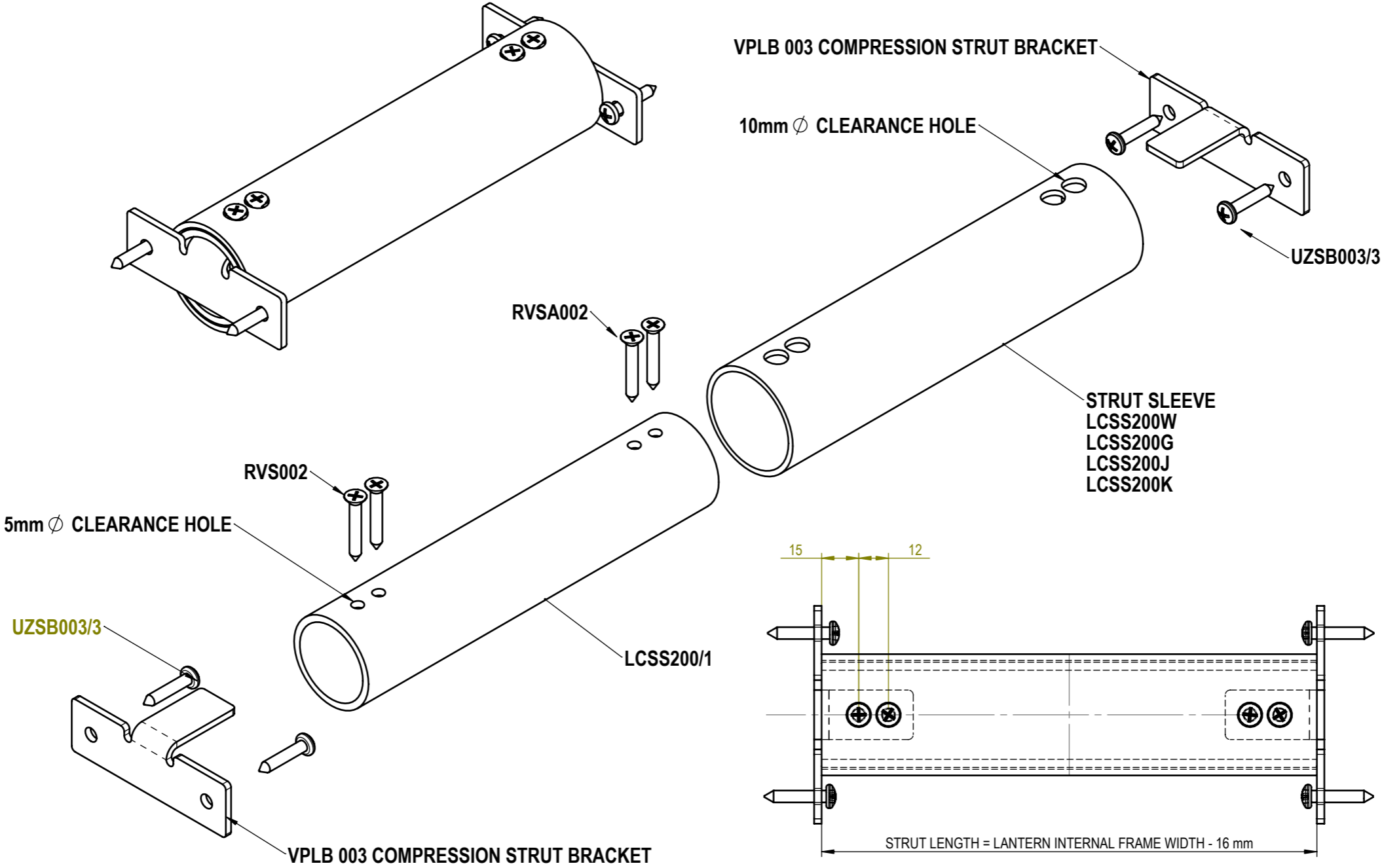

VPLB PREP FOR COMPRESSION STRUT

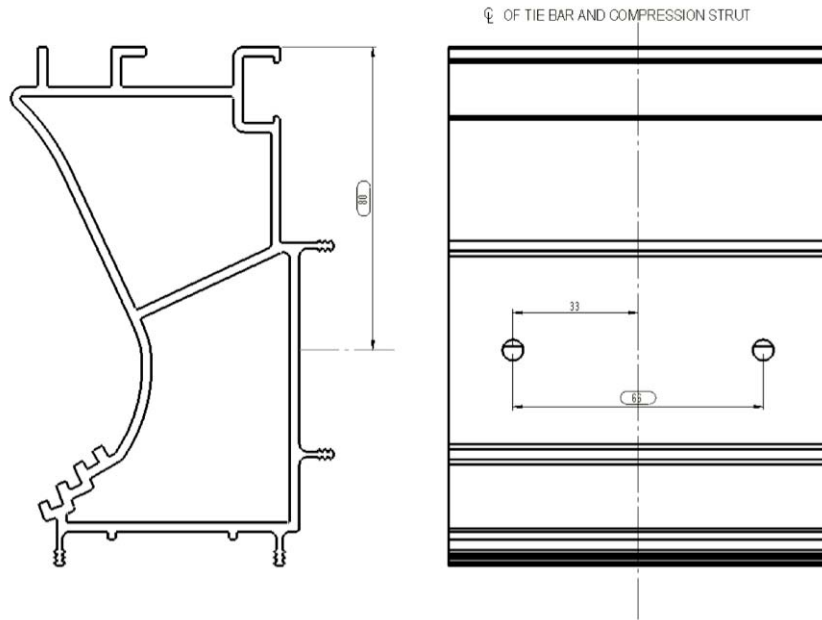

FASCIA PREP FOR COMPRESSION STRUT

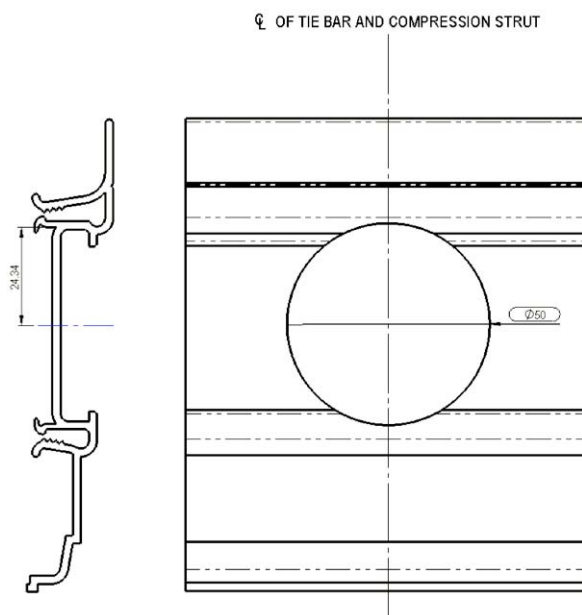

VPLB PREP FOR 5 WAY DROP ROD BRACKET VPLB 002

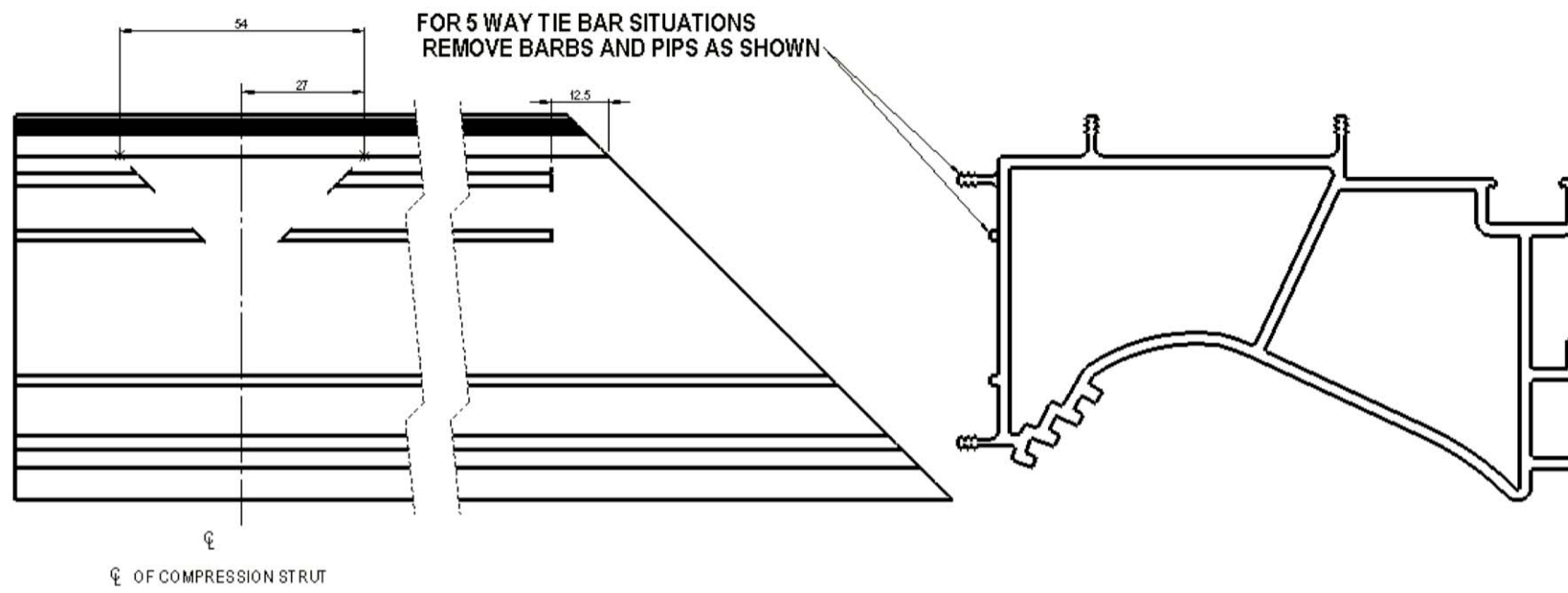

KHU PREP FOR 5 WAY DROP ROD SITUATIONS

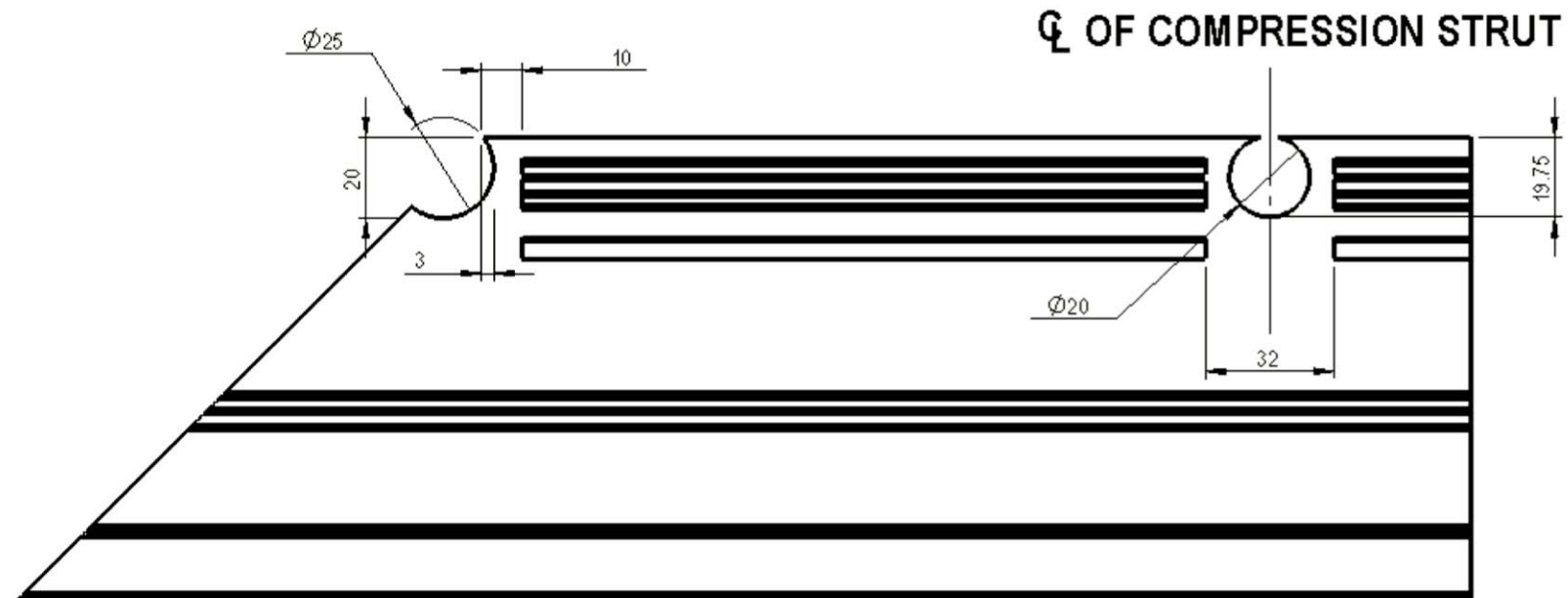

FITMENT OF VPLB002 5 WAY DROP ROD BRACKET

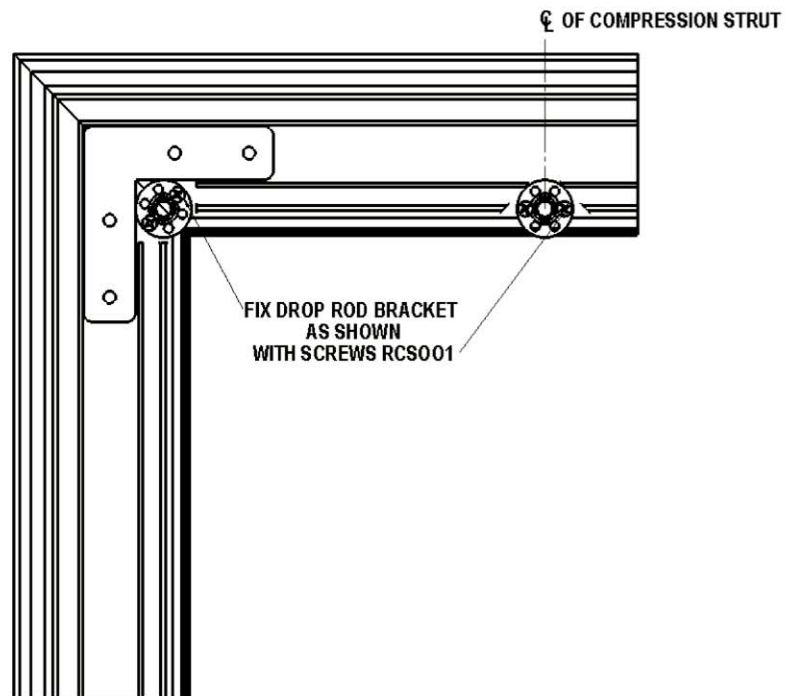

Technical Support

T: 0870 414 1008

F: 0870 414 1018

E: techsupport@ultraframe.co.uk



Ultraframe (UK) Ltd
Salthill Road,
Clitheroe,
Lancashire. BB7 1PE

Fabricator First Team
Installer First Team

tel : 08704 141006
tel : 08704 141002

www.ultraframe.com